



SOHware®

# BroadScan™ Security Appliances



*A Breakthrough all-in-one Security Solution for SMB  
Combining Performance, ease of use and affordability*

# BroadScan Security Appliances

## *Security with superior ROI*

- *Lower CapEx – Integrated all-in-one security features.*
- *Lower OpEx – Subscription-free signature updates.*



# Next Generation Security

*SOHOware Firewall legacy continues with the next level of security for SMB*

*BroadGuard - NBG800 and BCG700*  
First SPI Firewall Routers for Small Office

*BroadGuard - BBR1000 and BBR5000*  
First Intel IXP based SMB Firewall VPN Appliance

*BroadScan - SCN1000, SCL2000 and SCL3000*

Today's most cost effective UTM Appliance:

- Spam - Virus - Spyware filtering
- IDS/IPS - SPI Firewall
- VPN and WAN Load Balancing

*Coming in 2006 - DeepScan™ Internal LAN Security*

**1999**

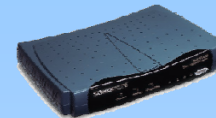

**2001**



**2003**

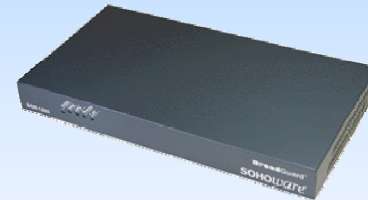

**Today**



# UTM - A Firewall Upgrade

BroadScan makes it easy for VAR's to offer outstanding security as an upgrade to their client's existing Firewalls.

- *Total threat control*
- *Subscription-free updates*
- *No added IT requirement*
- *Network flexible*
  - Configurable NAT policy routing
  - Drop in replacement to existing firewall

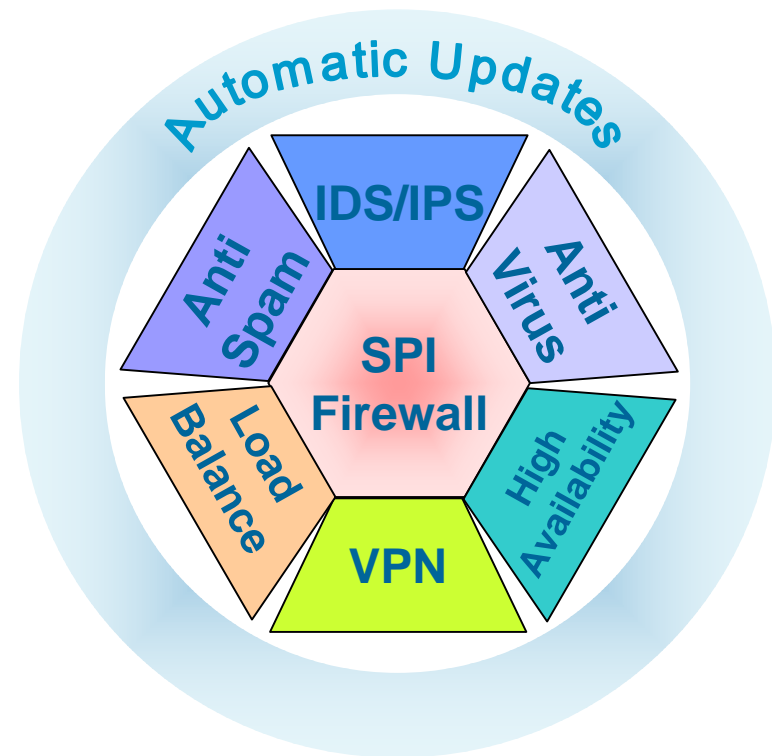

# Eliminating Barriers for SMB

**Firewall Alone**  
*Inadequate*

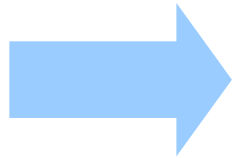
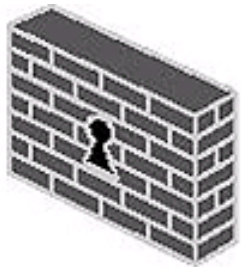

**Dedicated Appliances**  
*Cost Prohibitive and Complex*

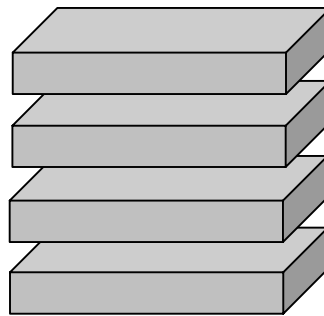

Firewall  
Anti-Virus  
Anti-Spam  
IDS-IPS  
VPN

**BroadScan  
UTM Appliance**  
*Highest ROI Value*



**“[UTM] appliances give businesses control over their assets without much hassle. ... It’s only a matter of time before more businesses drop their traditional firewalls in favor of UTM security appliances.”**

*One-Stop Security*  
*June 2005 by*  
*Oliver Kaven*



# Intelligent Scanning Engines

- *Behavior analysis based on Heuristics*
- *Bayesian self-training of signature databases*
- *Personal and global rule options*
- *White and Black lists*
- *Leading Open Source Engines:*
  - *ClamAV*
  - *SpamAssassin*
  - *SNORT*

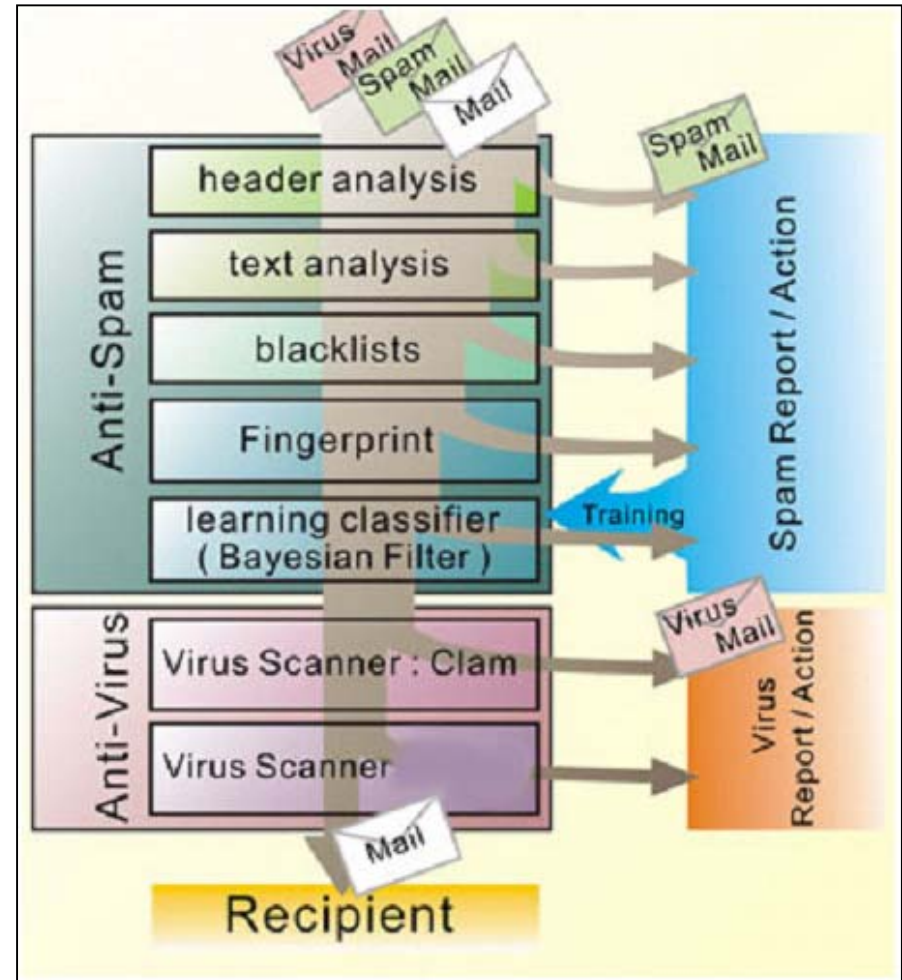



# Intuitive Management Tools

## CPU Utilization and System Health

## Email Filtering Statistics

## WAN Performance

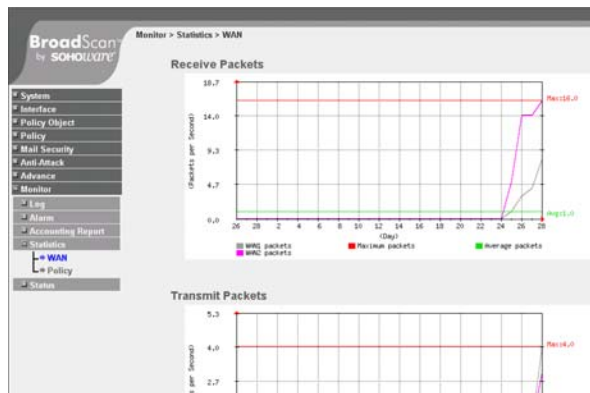
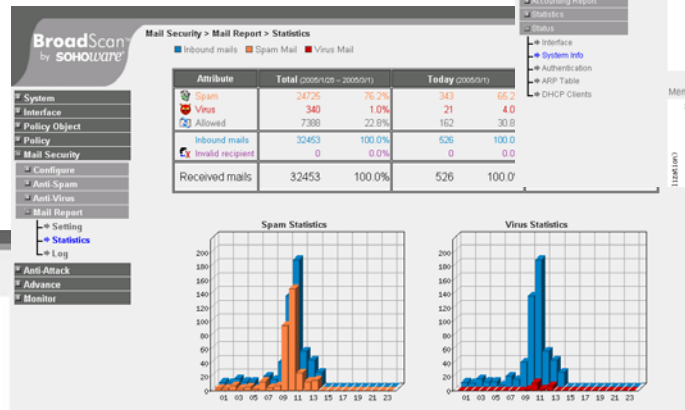
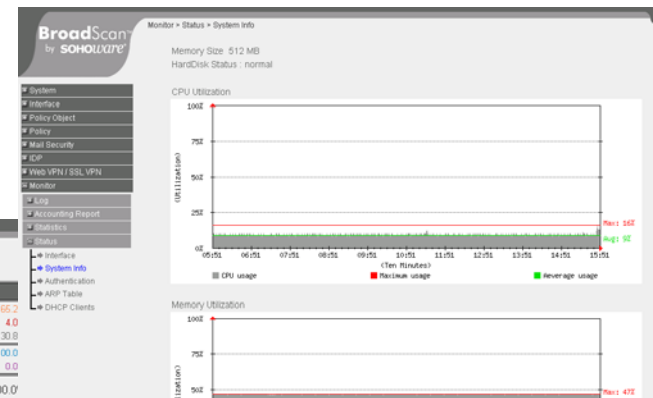

# BroadScan™ vs. Competition

## No Recurring Subscription or License Fees

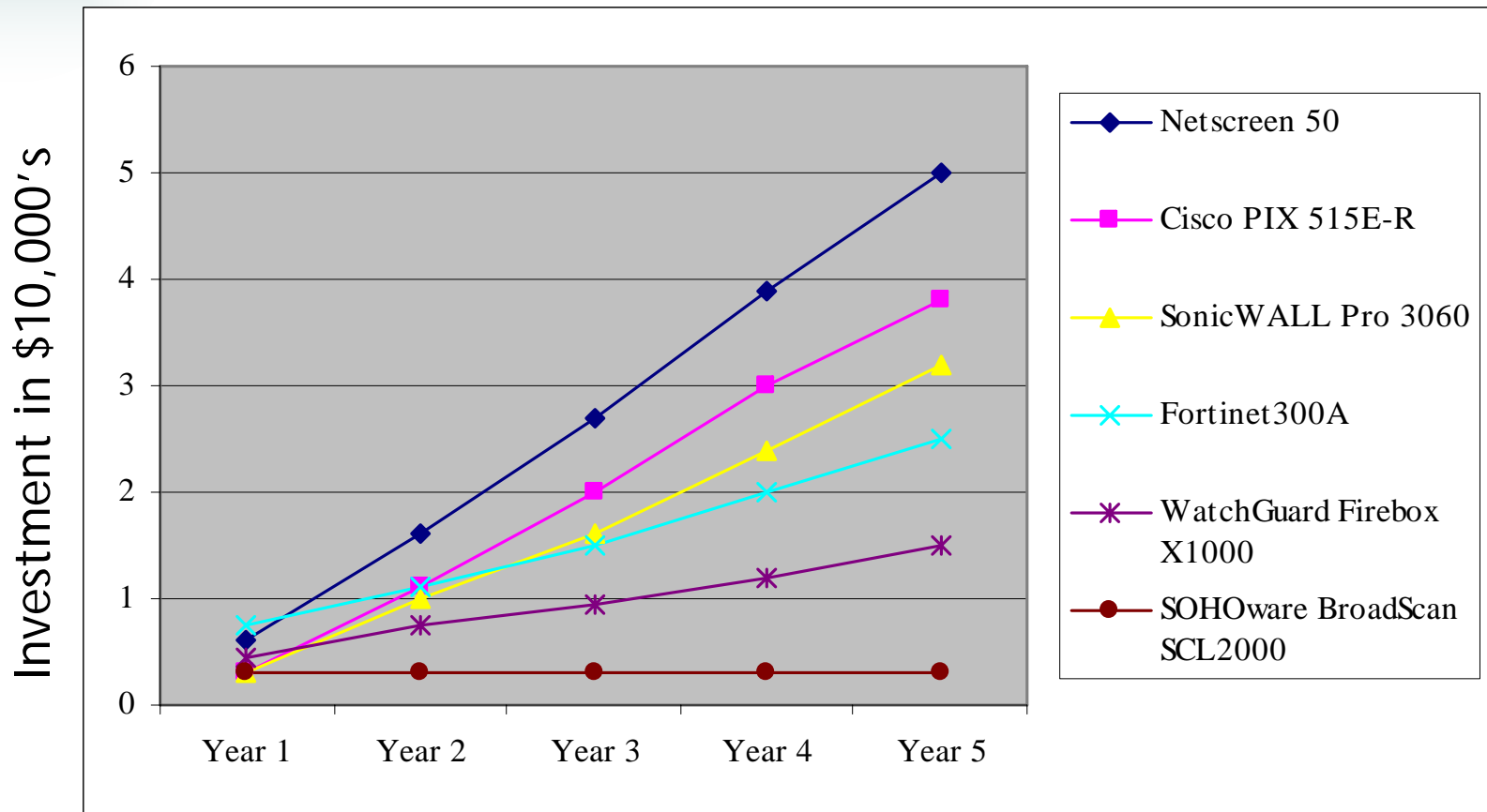

Typical Life-Cycle Cost: Appliance + Feature Enabling + Subscriptions

# Appliance Models

Performance	SCN200	SCN1000	SCL2000	SCL3000
10/100 Mbps (Throughput)	79.62 Mbps	100 Mbps	100 Mbps	100 Mbps
3DES VPN (Throughput)	15 Mbps	20 Mbps	45 Mbps	80 Mbps
Capacity (Email per day)	90,000	300,000	620,000	2,200,000
IDP signature database		2,918	2,918	2,918
Internal hard drive		40GB	40GB	80GB
Features	SOHO	SMB - Enterprise		
Network Size (number of nodes)	25	200	500	1000
Stateful Firewall	Y	Y	Y	Y
VPN Tunneling (IPSec/IKE / PPTP)	Y	Y	Y	Y
QoS	Y	Y	Y	Y
Anti Spam (email inbound/outbound)	Y	Y	Y	Y
Anti Virus (email inbound/outbound)	Y	Y	Y	Y
Content Filtering	Y	Y	Y	Y
Anti Spyware		Y	Y	Y
Intrusion Detection and Prevention (IDP)		Y	Y	Y
Anti Virus (HTTP/FTP)		Y	Y	Y
SSL VPN		Y	Y	Y
RADIUS Support		Y	Y	Y
Load Balancing (multiple WAN ports)			Y	Y
High Availability			Y	Y
VPN Trunking				Y
GigE Interface (10/100/1000 ports)				Y

# BroadScan All-in-one Security

## School Case Study

- Fiscal pressures motivated school district to seek subscription free solution.
- Alleviated roadblock of budgeting for recurring subscription costs.
- Eliminated inbound threats and outbound application mis-use (IM, FTP, Specified web sites).

### All-in-One Security Gateway Found to be Most Efficient Solution for School Computer Lab?



#### Elementary School Required to Meet District standards

An elementary school was in a tight fiscal predicament, needing to meet district security mandates with little added budget support.

#### VAR Achieves Fiscal Breakthrough

BroadScan™ eliminated need for a recurring subscription budget to maintain virus, Spyware and Intrusion signatures. The VAR was able to deploy comprehensive security and support services within the school's financial means.

#### Elementary School Computer Lab

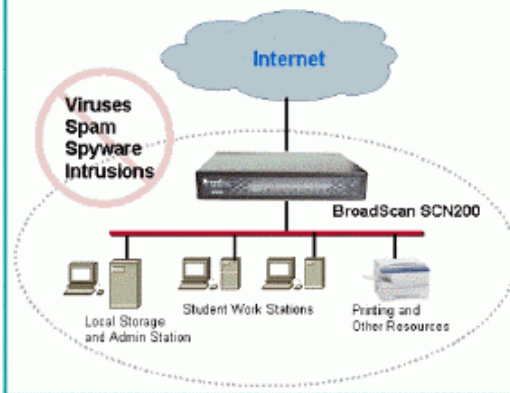

#### Eliminated Desktop Clients

The UTM gateway approach also eliminated the need for client station security software... a more efficient approach for the school's computer lab staff.

#### Learn More:

[Case Study for Computer Lab.](#)

[BroadScan All-in-One Security Appliances for small and medium business networks.](#)

[SOHware's QACIS architecture for SMB targeted solutions.](#)

[Contact Partner Marketing today!](#)

Subscription Information: You are receiving VAR Newsletter Update in response to registration. To unsubscribe, simply reply to this email and type "Unsubscribe" in the subject line.

Copyright (c)2005, SOHware, Inc. [Privacy Statement](#)

**SOHware**  
Your partner for SMB networking

# MTU Campus Case Study

- Integrates BroadScan with AeroExtend outdoor wireless at townhouse property.
- WAN load balancing supported fault tolerant Internet reliability.
- Embedded anti-spam & virus filtering was a value add selling point for ISP that enhanced acquisition of new subscribers.

## WISP Discovers Better Subscriber Acquisition With BroadScan™ Virus and Spyware Filtering



### Staying Competitive with Carriers

With the pressure on to capture new high speed Internet subscribers, WISPs are taking the initiative to stay ahead of carrier based services.

### Subscribers Attracted to Value

The integrated security features of BroadScan™ enabled the WISP to up their conversion rate by offering Virus and Spyware blocking along with Internet services.

### Pays for Itself Within 12 Months

WISP achieves secure MTU deployment by pairing BroadScan™ with outdoor ready AeroExtend™ WLAN for a secure Wi-Fi Internet access solution.

### Read More:

[Case study on increasing subscriber conversion rates with value added security.](#)

[BroadScan All-in-One Security Appliances for small and medium business networks.](#)

[SOHware's OACIS architecture for SMB targeted solutions.](#)

[Contact Partner Marketing today!](#)

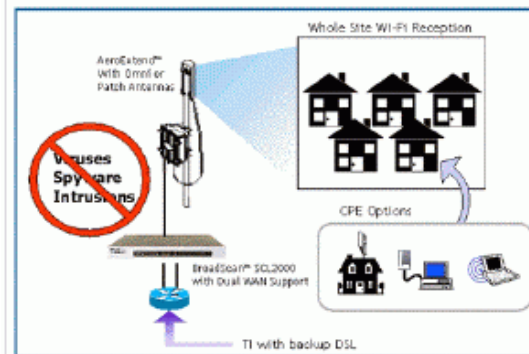

Subscription Information: You are receiving VAR Newsletter Update in response to registration. To unsubscribe, simply reply to this email and type "Unsubscribe" in the subject line.

Copyright (c)2005, SOHware, Inc. [Privacy Statement](#)

**SOHware**  
Your partner for SMB networking

# BroadScan™ Opens Security Opportunities

## *BroadScan™ UTM Security for SMB networks*

- All-in-One security functions in one appliance
- Automatic signature updates with no recurring fees

## *SOHware VAR exclusive Design Win Support*

- One on one Application Engineering guidance
- 888-785-8222 is your technical support line
- Support@sohware.com

## *Contact our VAR Partner Marketing Executives*

**800-632-1118**

**www.sohware.com**